



Fabio Lettieri

Introduction

Fabio Lettieri is an IP, trade mark and patent expert with more than 25 years experience. Covered the position of Licensing Director for Iconix Brand Group which helped to reach in 2009 \$ 14 billion in total sales with 82% EBITDA. Iconix in 2009 was nominated the second largest company in the world for royalties generated by licensing deals. In 2010 founded Interface 212 which have created the snorkeling mask by Decathlon among other projects: Soda Stream, Holo and IPPS, new technology for parking sensor which was on the TV show: **Shark Tank**.

Over 25 years of experience Fabio Lettieri has signed more than \$ 69 million in contract guaranteed royalties. Before the licensing world Fabio Lettieri has worked in Textile, creating projects that have become international success.

Father of three children, Fabio Lettieri is very active in the charity world.

In 2002, Fabio Lettieri and his friend Aldo Forte organized an international soccer tournament to commemorate the victims of the 9/11 tragedy. The tournament was a success, raising **\$2 million for New York City**.

Track records

In his career Fabio Lettieri signed more than \$ 69 M in royalties guaranteed contracts in more than 40 countries around the world.

Fabio Lettieri is an expert of **European** and **North America** markets as well as emerging markets like **India**, **China** and **South America**.

Highlights

Brands

Ocean Pacifics
Rock&Republic
Vera Weng
Havaianas

Patents

V16 + Holo
IPPS - Shark Tank
Snorkeling Mask
Smart Band-Aid

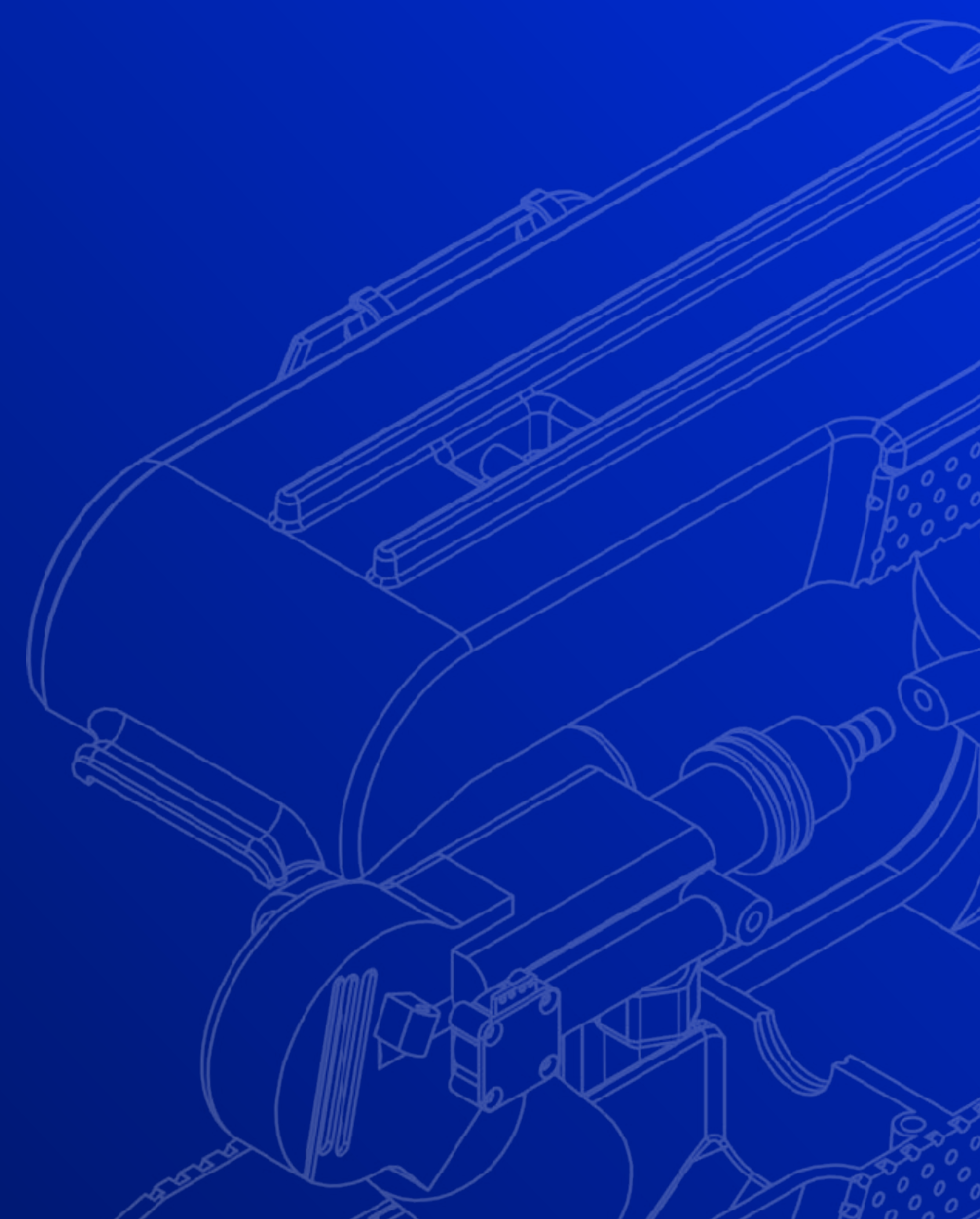
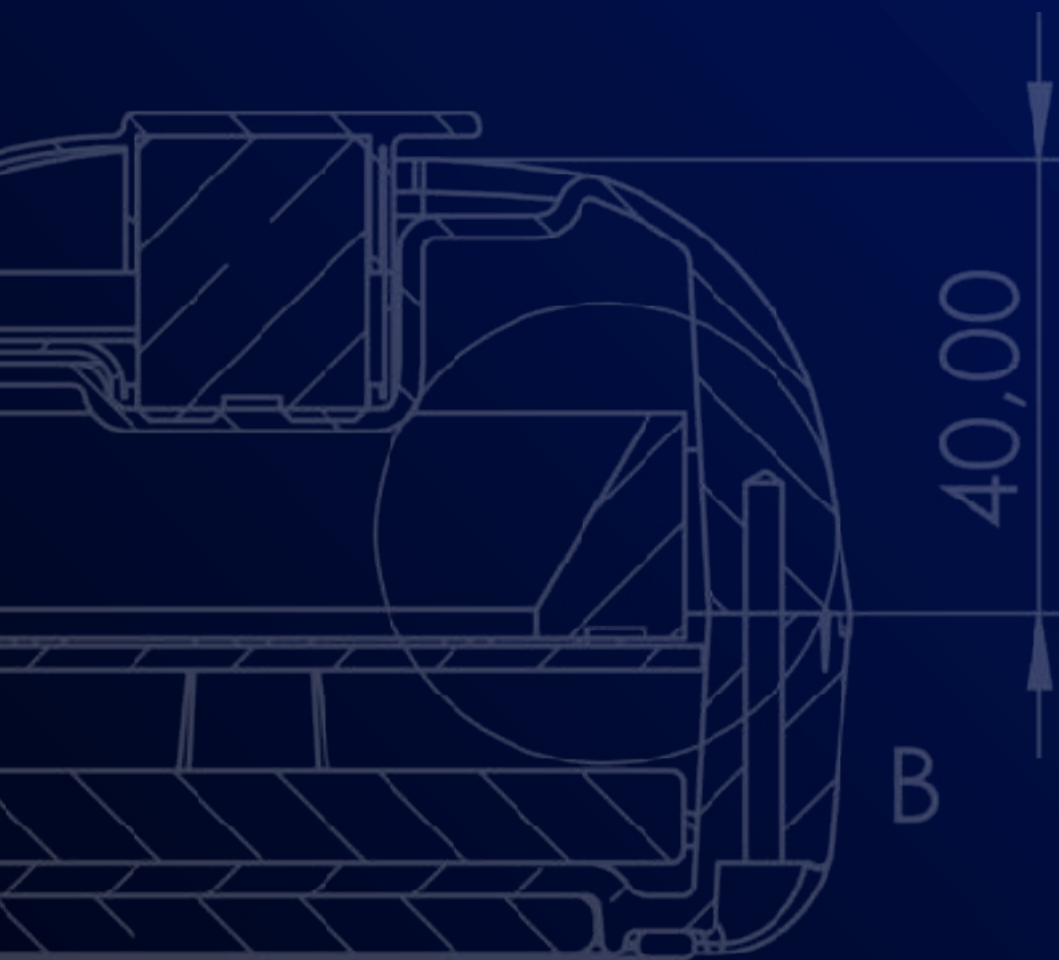

Brands

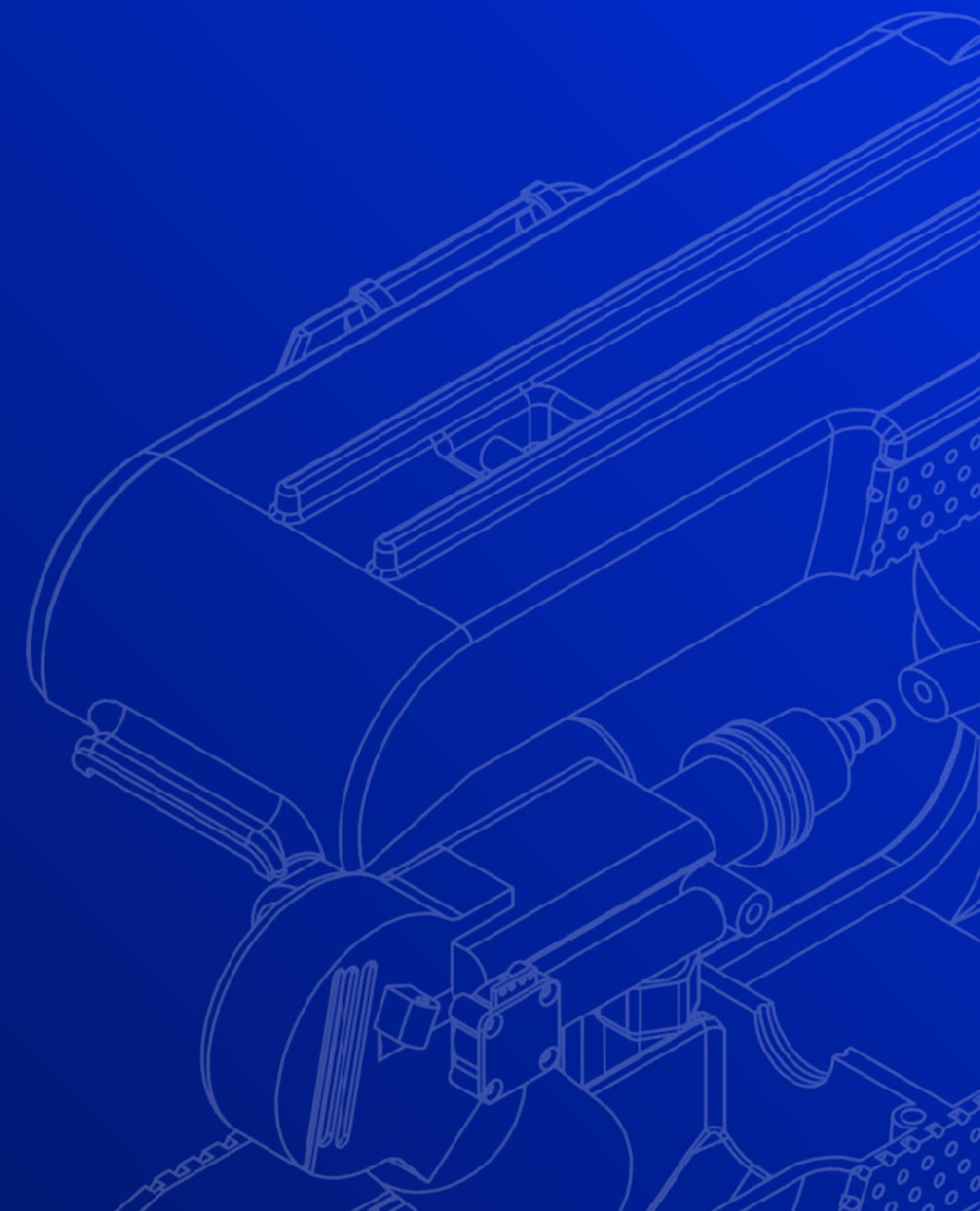
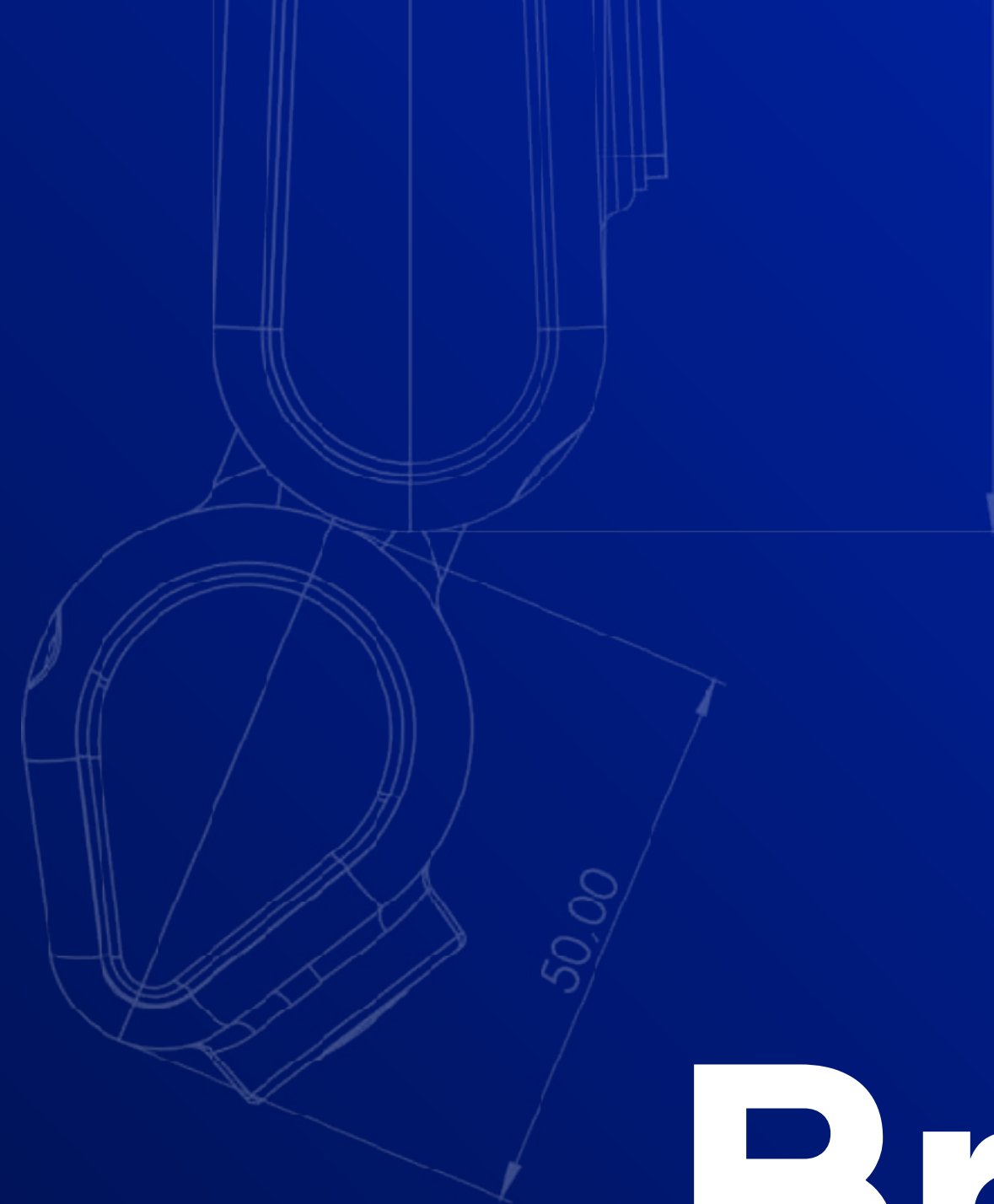
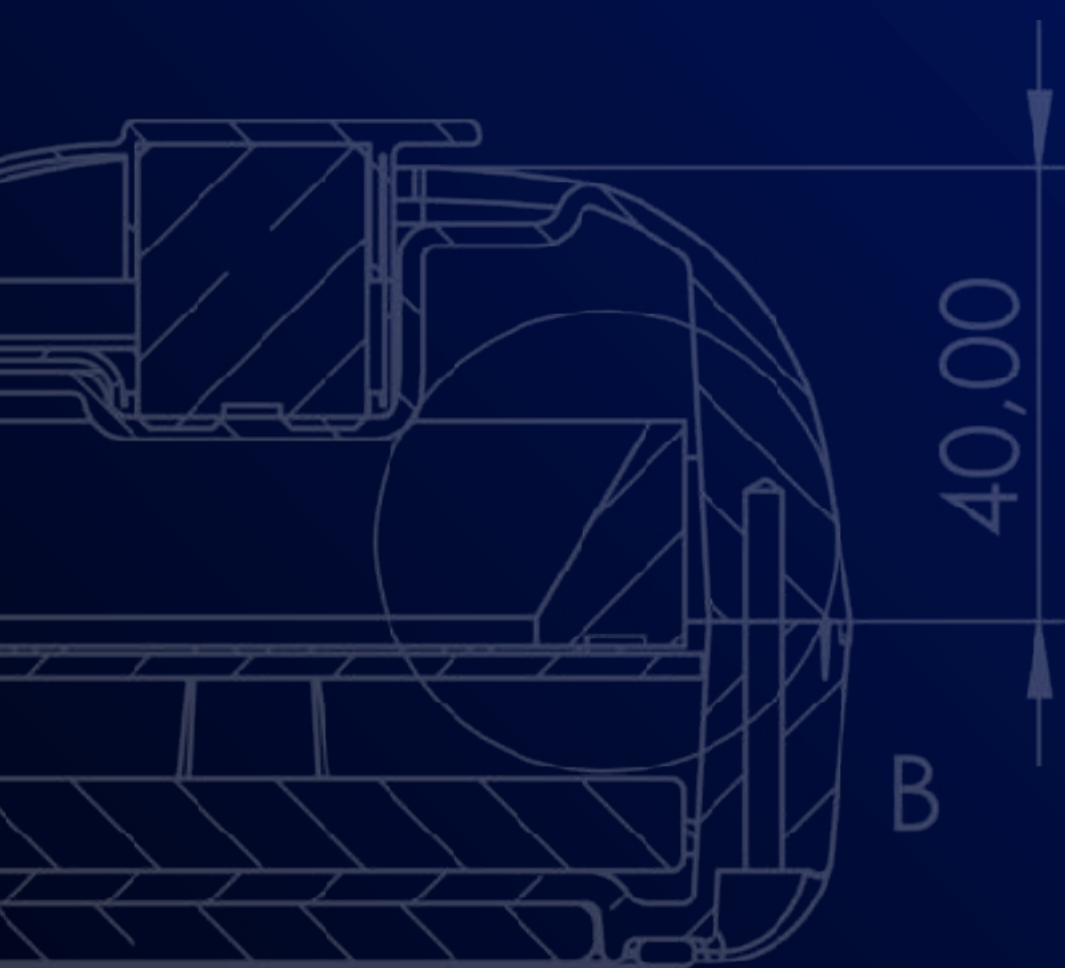



- IP Bought by Iconix for: **\$ 28 million**
- License agreement: **5 Yrs + 5 Yrs**
- Min. royalties guaranteed/year : **\$ 7 million**
- Actual royalties paid per year: **\$ 25 million**

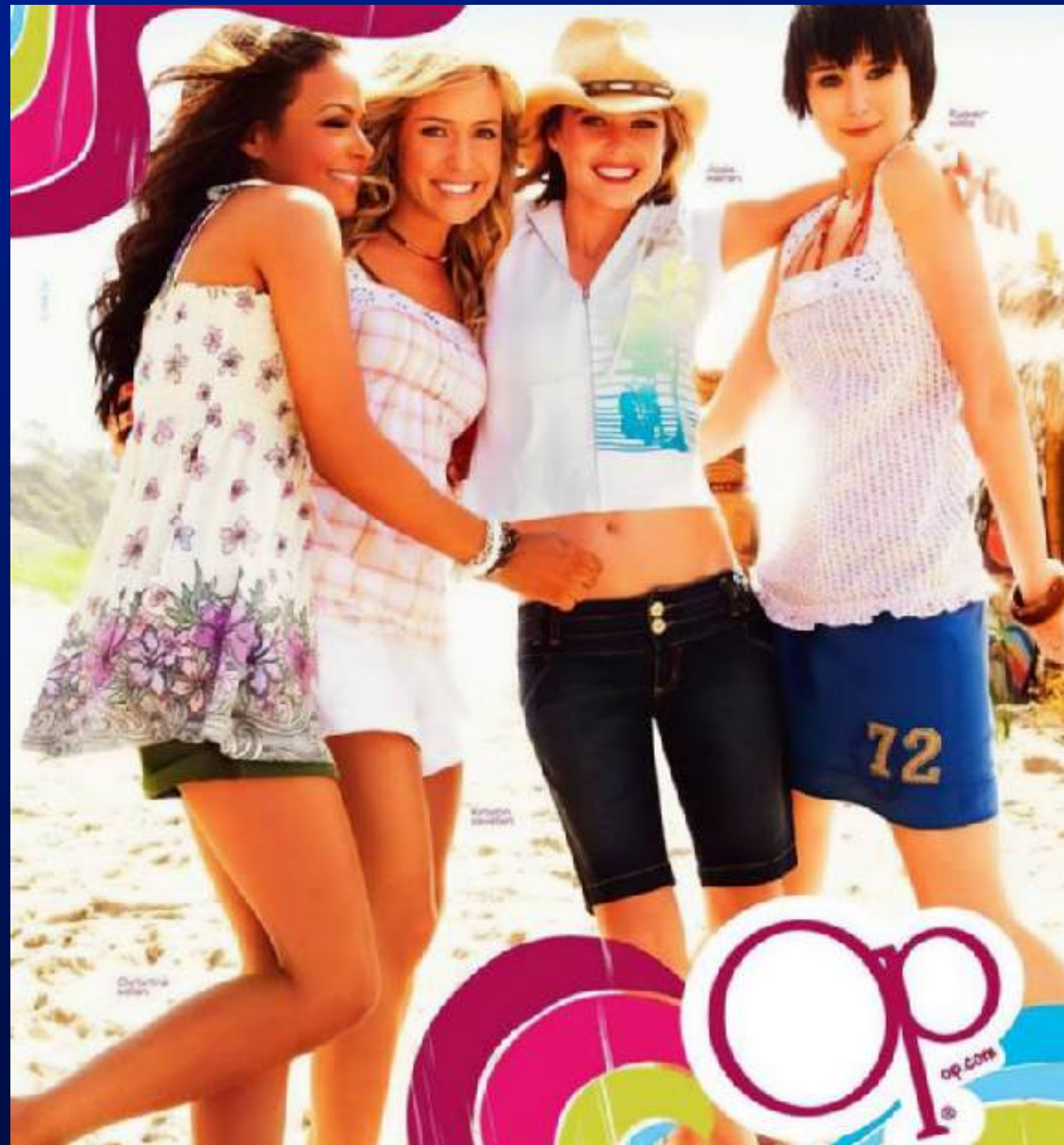



ROCK & REPUBLIC

- IP bought for **\$ 60 million** by VF
- License agreement: **5 Yrs + 5 Yrs**
- Min. royalties guaranteed: **\$ 12 million**
- Actual royalties paid per year: **\$ 28 million**





Before: \$ 40 million revenues

SIMPLY VERA VERAWANG

The collection exemplifies everyday sophistication and accessible luxury. Simply Vera Vera Wang is designed for those who appreciate effortless style and know that it is the small signature details that make all the difference.



After: Simply Vera by Vera Weng
\$ 280 million with 5% royalties

havaianas



Before Interface 212

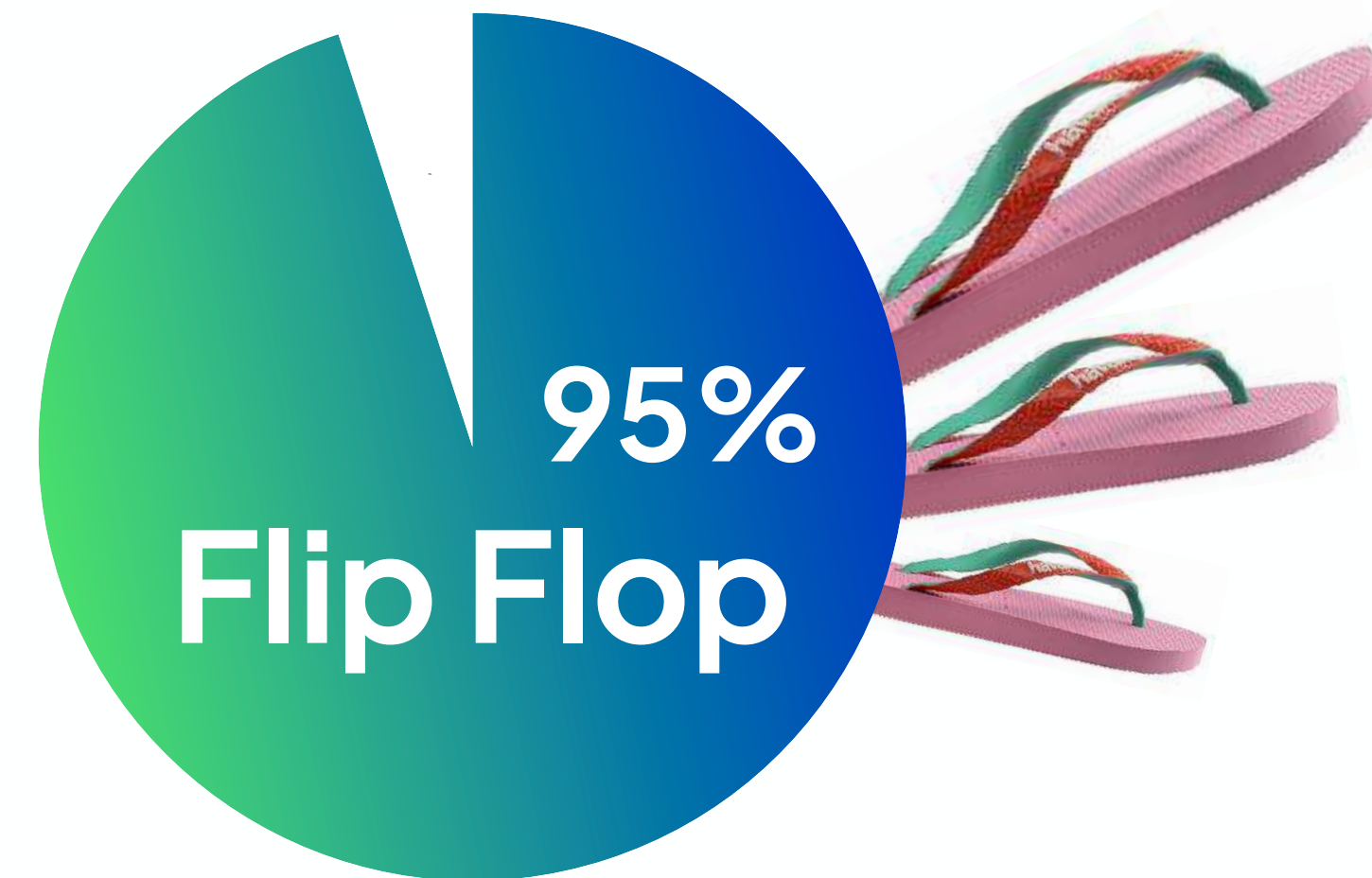

With Interface 212

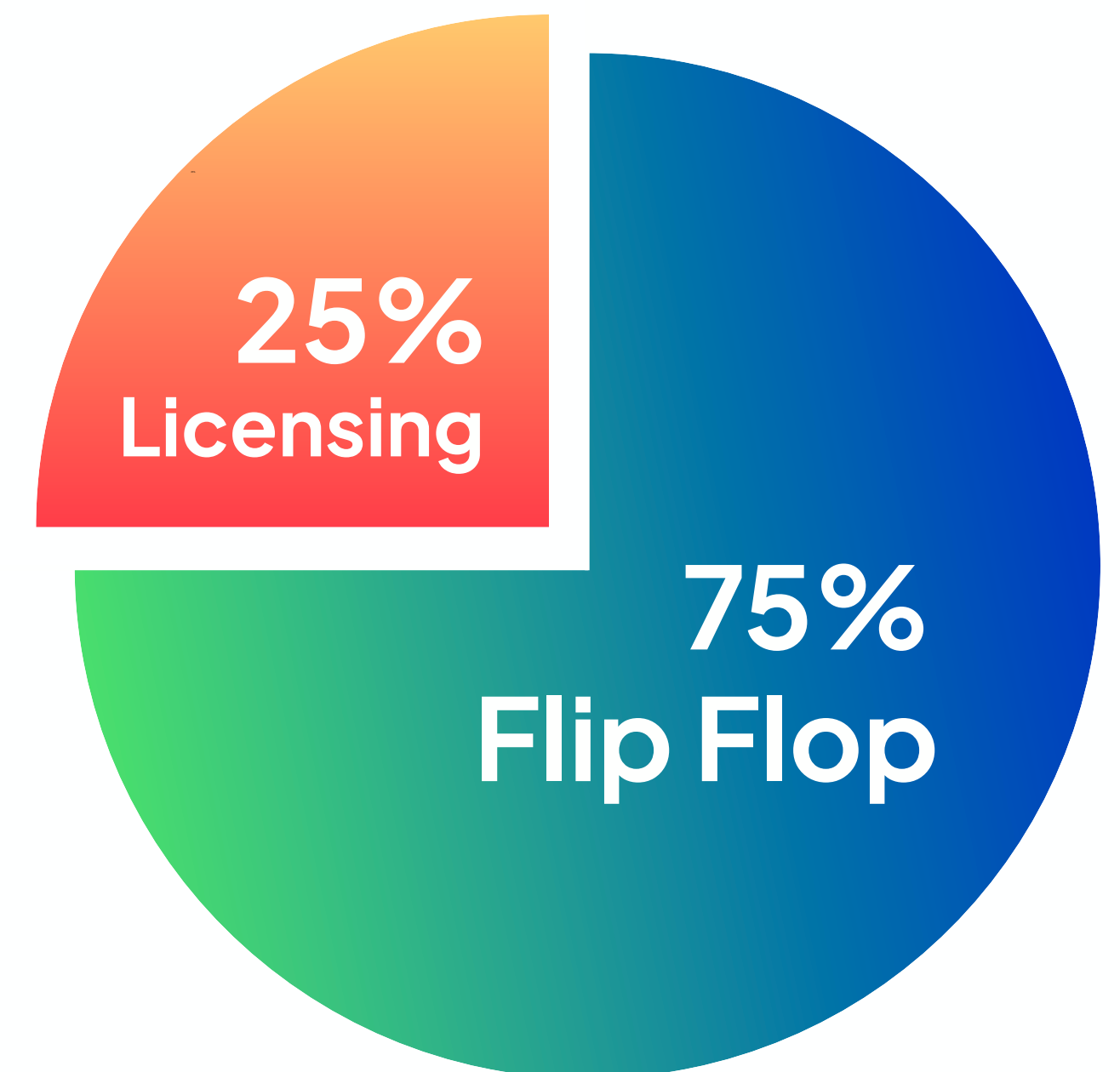

Patents

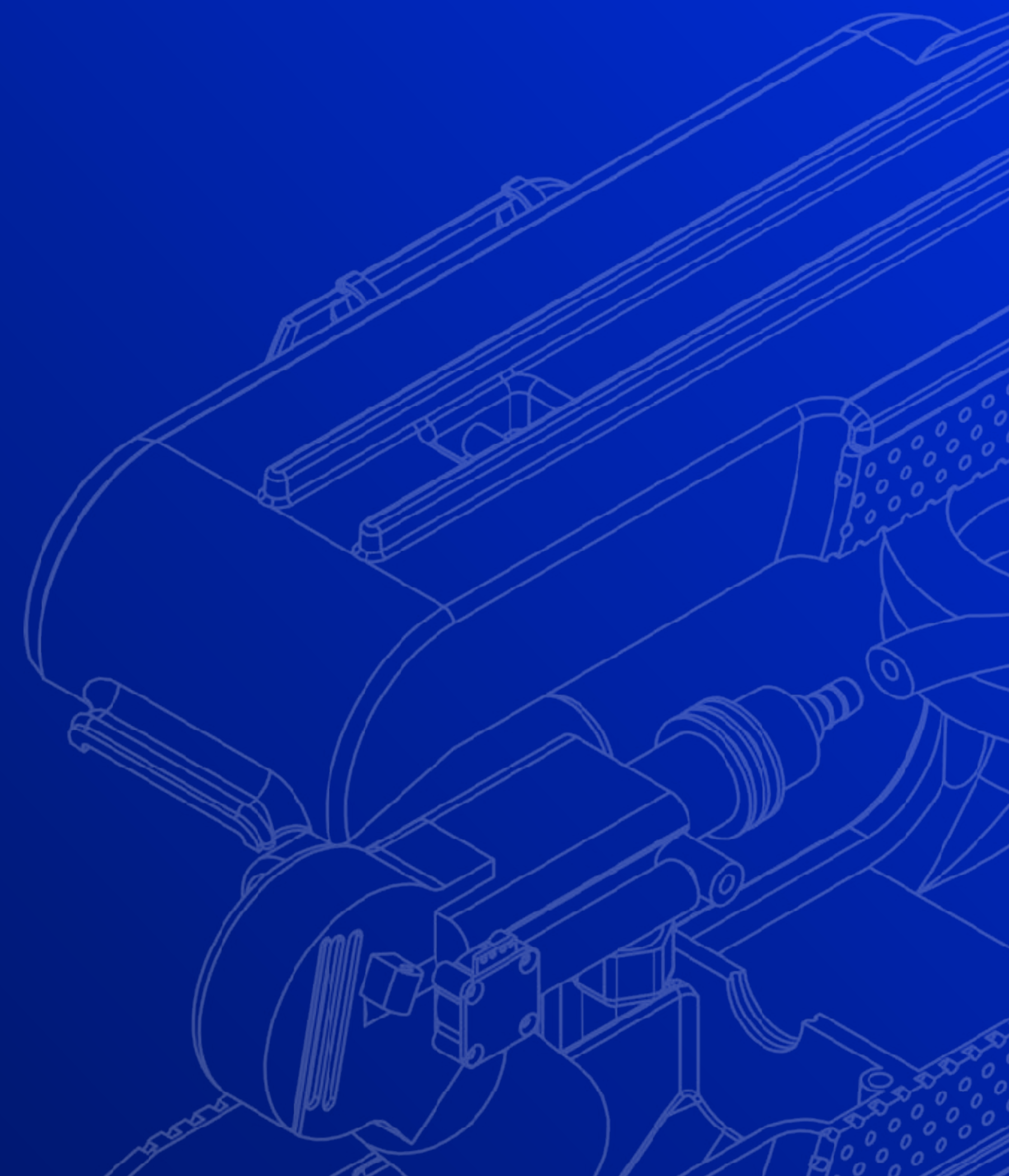
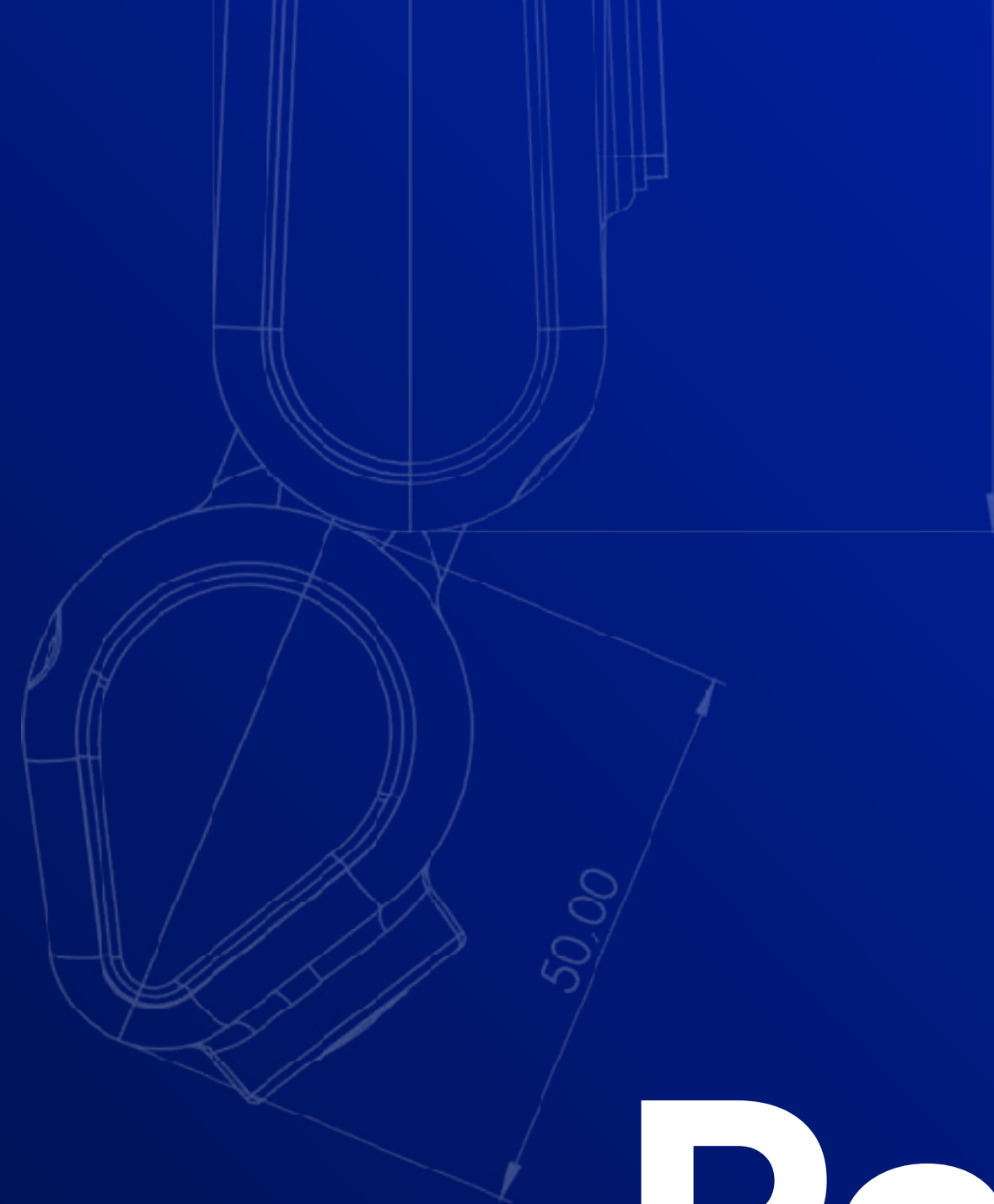
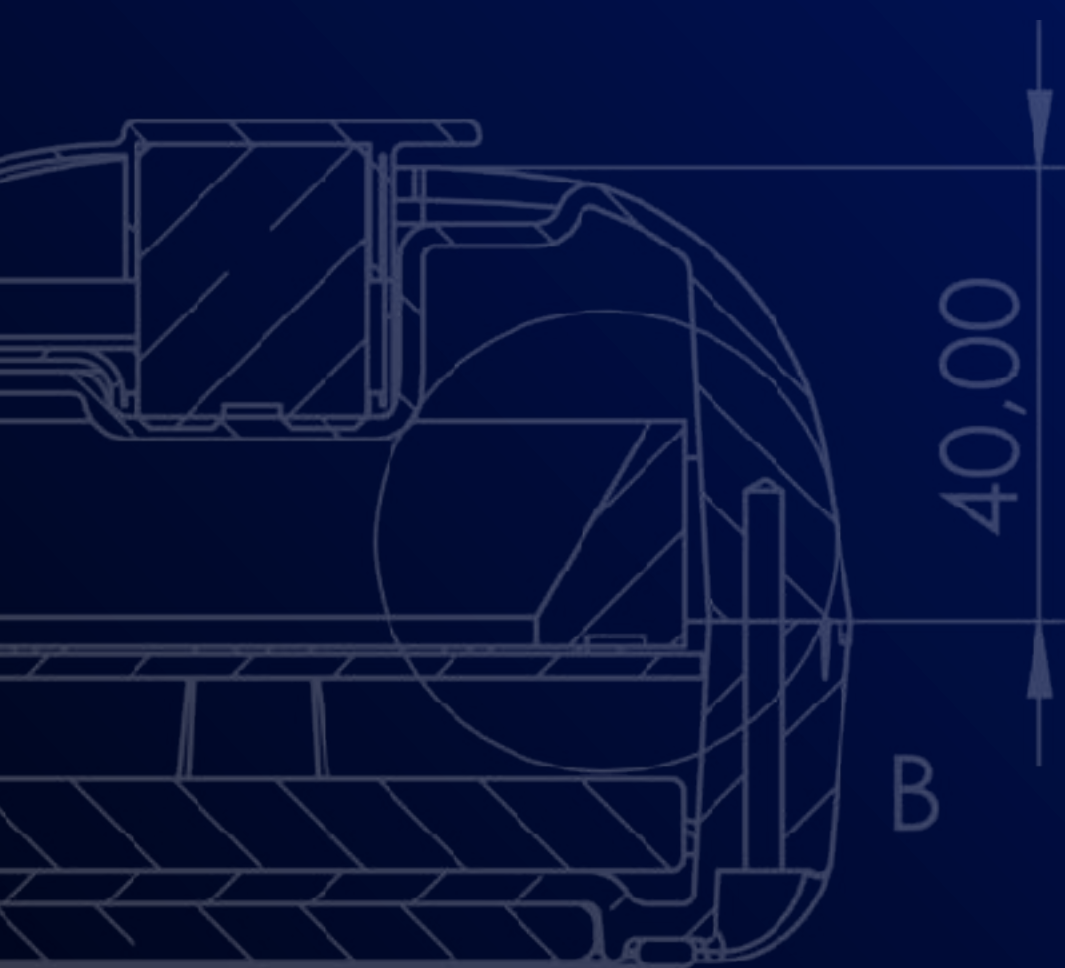

V16 + Holo

V16+HOLO device combines a V16 flashing beacon device with a holographic projector that can produce a hologram of the emergency triangle through a laser beam.



2024

From 2024 Spain and UK will replace the old warning triangle with the V16 flashing beacon.



IPPS – Infrared Shark Tank



- Total investment: **Eu 330.000**
- Project revaluation after 18 months **Eu 4.8 million**
- 12% sold for **Eu 500.000**

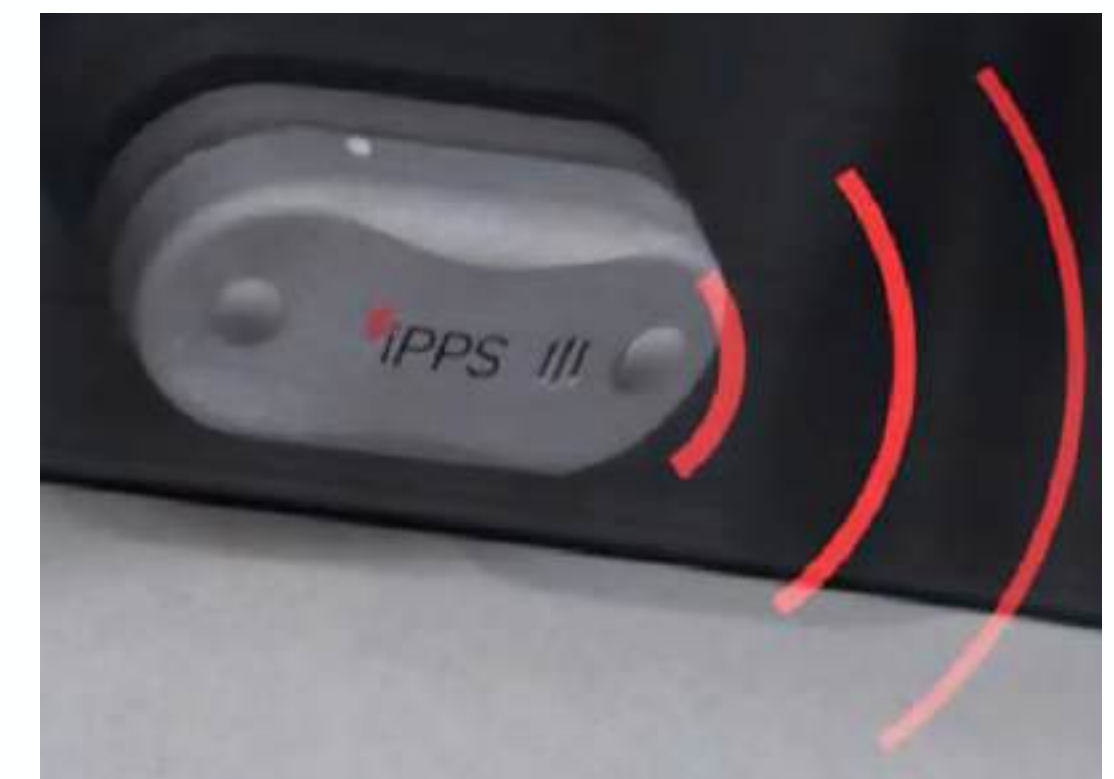
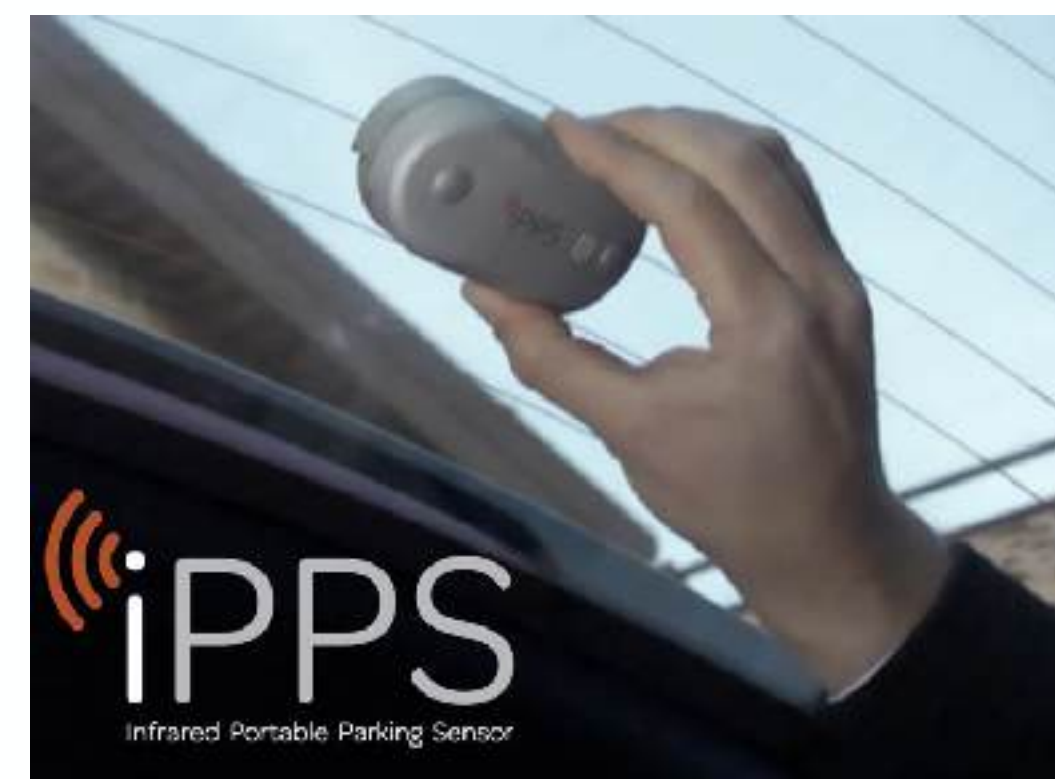

Easy breath Mask



DECATHLON

- Fabio Lettieri (through Interface 212) participated in the industrialization:
6 months: Production costs Eu 7.25
- DTR (direct license agreement) signed with Decathlon
12 months: Retail price Eu 29



Smart Band-Aid

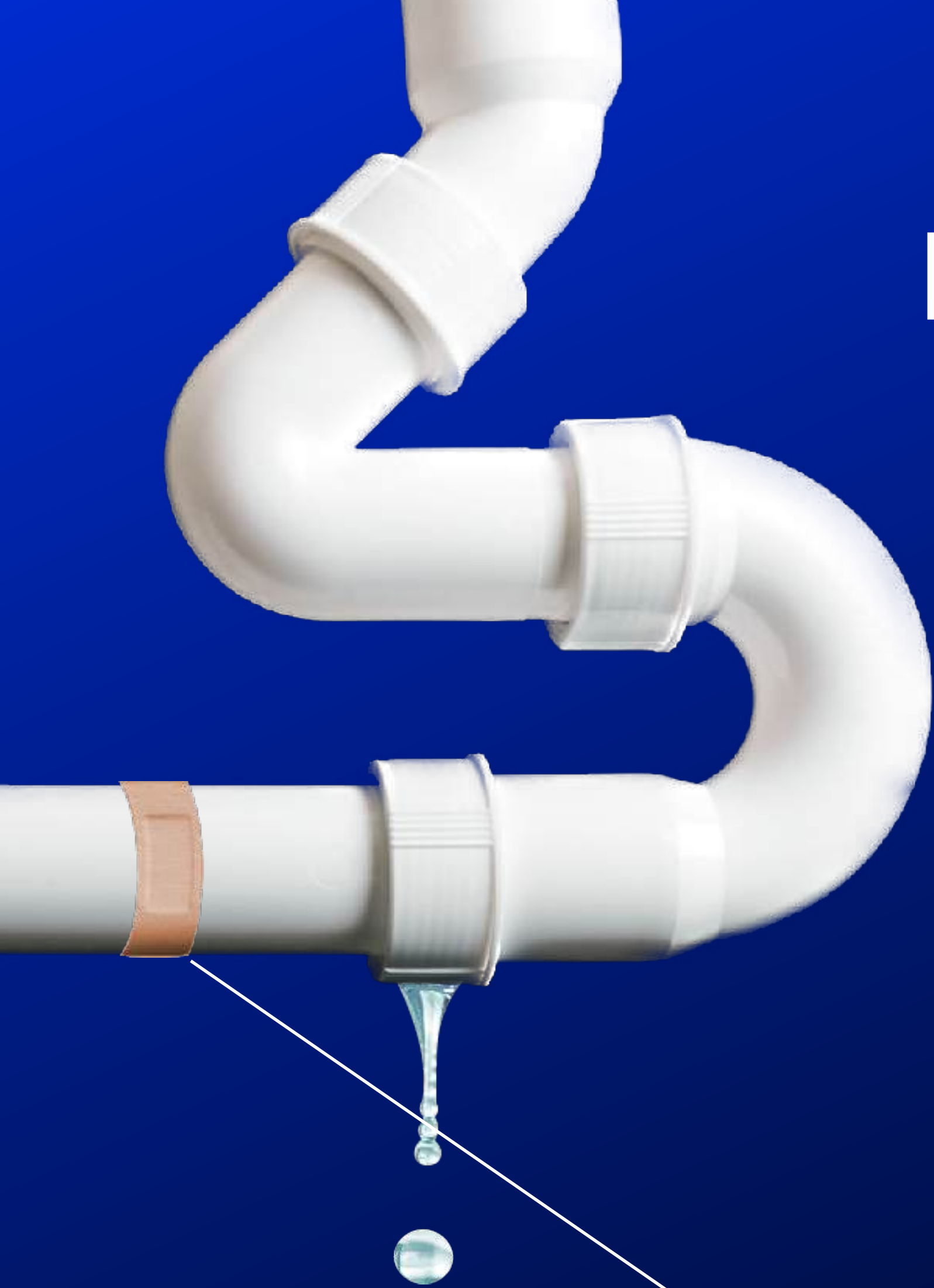

How it was
to read water waste



How we made it

We used the technology of the Band-Aid
to read and monitor breast feeding



Other Projects



TATA

**RANGE
ROVER**



JAGUAR



sodastream®

sodastream

sodastream



JOE BOXER[®]

MOMA
design
MOMA
materialofmodernarchitecture



The new *Allitalia*



Thank you



Born

August 27th, 1974

Mail

flettie@gmail.com

Mobile

+39 320 8763 907